

Digital Cabinets

1-door Thawing Cabinet, 670lt, 60Hz on wheels, R290

ITEM # _____

MODEL # _____

NAME # _____

SIS # _____

AIA # _____

725191 (TC671DH60)

 1-door Thawing Cabinet, 10
 stainless steel grids, 670lt,
 0+10°C, AISI 304, R290
 (60Hz)

Short Form Specification

Item No.

Full door thawing cabinet mainly constructed in A304 stainless steel for everlasting operation in all working environments. Fully pressed bottom plate and rounded corners; it is supplied with 10 AISI 304 grids 2/1 and the rack support can be removed without tools.

Control panel indicating the real temperature evolution of the cabinet during the preservation process. The electronic control switches automatically from thawing into preservation to avoid bacteria proliferation. It is fully customizable in time, temperatures and thaw/preservation split of phases.

Factory-preset and free program to cope with loads from approx 20kg to 80kg.

Built-in refrigeration unit with R290 gas in refrigeration circuit.

Meets HACCP requirements.

Delivered on wheels.

Main Features

- 3 factory-preset and 1 free program to cope with loads from approx 20kg to 80kg. All programs are customisable in time, temperatures and thaw/preservation split of phases.
- Cabinet fitted with up to 75 mm thickness of cyclopentane insulation for best insulating performance with 100% environmental protection (thermal conductivity: 0,020 W/m*K).
- Powerful fan to ensure a quick and uniform thawing process.
- Fully HACCP compliant thanks to the temperature control, visualisation and alarm management.
- Fully customisable parameters to suit even the most demanding needs.
- Temperature display shows real temperature evolution allowing for frequent and brief checks during the thawing-preservation process.
- The electronic control switches automatically from thawing into preservation to avoid bacteria proliferation.
- Even airflow ensured by back air conveyor and ensuring consistent results on products to be thawed in a single load.
- 10 AISI 304 grids GN 2/1 supplied as standard to maximise internal space.
- The rack support can be removed without tools to speed up cleaning operations and they are dishwasher safe.
- Tropicalized unit.

Construction

- Mainly construction in A304 stainless steel for everlasting operation in all working environment.
- Fully pressed bottom plate and rounded corners for easier cleaning.
- 4 wheels (front ones with brakes) are supplied as standard to ease cleaning operations.
- Developed and produced in ISO 9001 and ISO 14001 certified factory.
- Integrated security lock.

Sustainability

- CFC, HCFC, HFC-free insulation.
- CFC and HCFC free, highly ecological refrigerant type: R290 (ecological gas in foam: cyclopentane). Hydrocarbon refrigerant gas R290 for the lowest environmental impact (GWP=3), to reduce green house and ozone depletion effects.



APPROVAL: _____

Included Accessories

- 1 of 4 swivelling wheels (2 with brake), PNC 881002
diam 125 mm, for refrigerators, NOT for
remote models
- 10 of 2/1GN aisi 304 stainless steel grid PNC 881016
- 1 of Collecting tray in AISI 304 stainless PNC 881203
steel for Thawing Cabinet
- 1 of Shelf support with 10 positions for PNC 881291
Thawing Cabinet

Optional Accessories

- Spacer for 670 lt and 1430 lt PNC 880248
refrigerated cabinets
- 2/1GN aisi 304 stainless steel grid PNC 881016
- Internal back air baffle/conveyor for 15 PNC 881201
grids Thawing Cabinet
- Internal back air baffle/conveyor for 10 PNC 881202
grids Thawing Cabinet
- Collecting tray in AISI 304 stainless PNC 881206
steel for Thawing Cabinet with internal
back air baffle/conveyor
- Kit 4 feet h. 100 mm for Thawing PNC 881240
Cabinet
- Shelf support with 15 positions for PNC 881290
Thawing Cabinet

Front

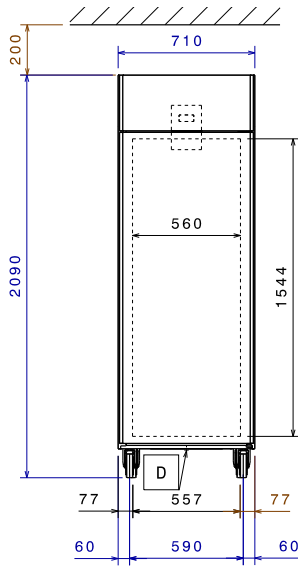

Side

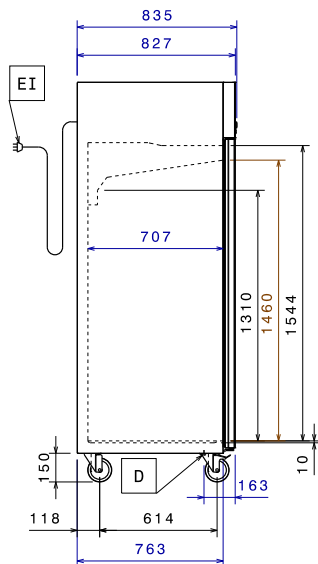

EI = Electrical inlet (power)

Top

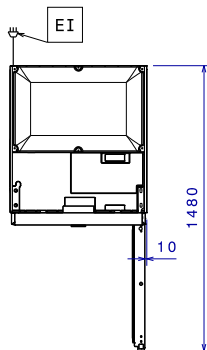

Electric

Supply voltage:

725191 (TC671DH60) 220-230 V/1 ph/60 Hz

Electrical power max.:

1.73 kW

Key Information:

N° of doors:	1
External dimensions, Width:	710 mm
External dimensions, Depth:	835 mm
External dimensions, Height:	2090 mm
Internal Dimensions, Width:	560 mm
Internal Dimensions, Depth:	707 mm
Internal Dimensions, Height:	1460 mm
Net weight:	149 kg
Type of external material:	304 AISI
Type of internal material:	304 AISI
External side panels:	304 AISI
External top panels:	304 AISI
External door material:	304 AISI
Internal panels material:	304 AISI
Back panel:	Galvanized Steel

Refrigeration Data

Control type:	Digital
Compressor power:	1/4 hp
Refrigeration power at evaporation temperature:	-10 °C
Operating temperature min.:	0 °C
Operating temperature max.:	10 °C

ISO Certificates

ISO Standards: ISO 9001; ISO 14001; ISO 45001; ISO 50001

Sustainability

Noise level:	54 dBA
Refrigerant type:	R290